



## Adjustment of the clutch

### Re-adjusting the clutch

- Remove electric winch from the mounting support by operating the knurling screw
- Remove the cover of the casing
- Prevent turning of the worm gear by sticking a pin (or small screw driver) into the small hole of the winch casing and further into the hole of the worm gear casing up to the gearing of the worm wheel to lock it by the pin.
- After that you are able to turn the self-locking nut of the clutch for its new adjustment

### If biting point of the clutch is too low:

- Proceed step by step: turn the self-locking nut of the clutch to the right (clockwise) in steps of 5 degrees until the slipping of the clutch occurs at a pulling force of about 4 kp. Measure the pulling force by a spring balance.

### If biting point of the clutch is too high:

- Turn self-locking nut step by step to the left (anticlockwise).

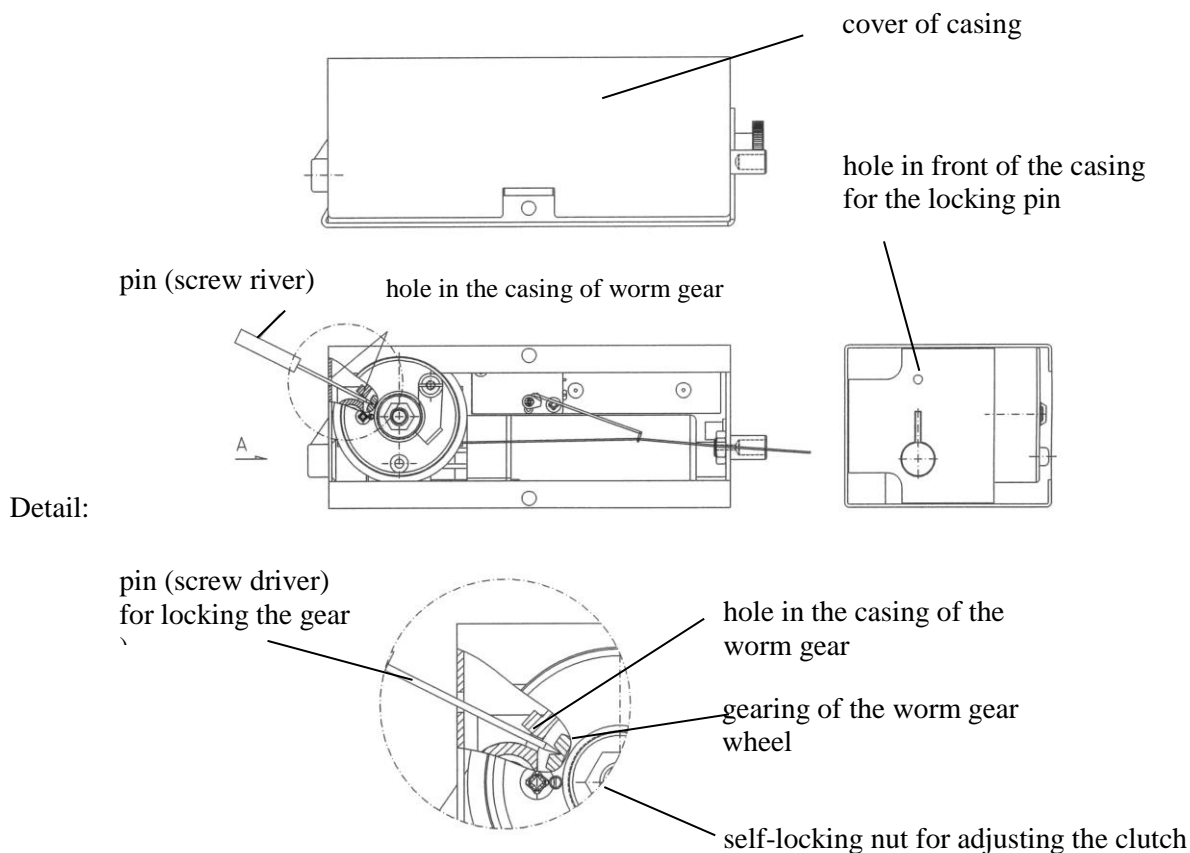

Adjust maximum pulling force on the retrieval line by the use of a spring balance

